

X-Bar IVRA-210

IP Video Redundancy Appliance

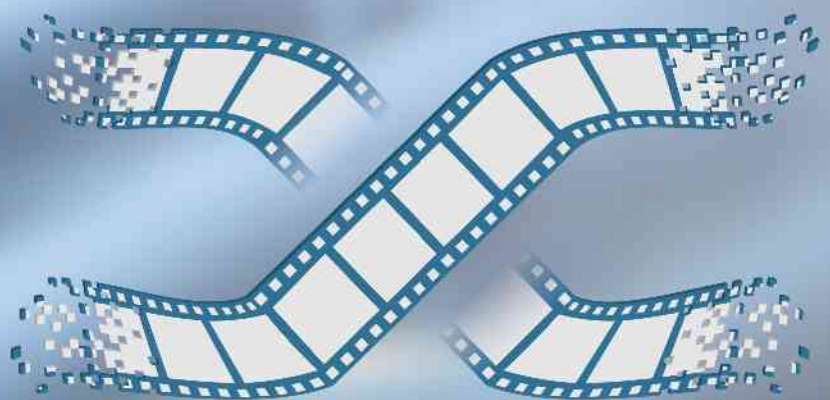

X-Bar IVRA-210 *IP Video Redundancy Appliance*

The GMIT X-Bar IVRA-210 is an advanced network device for improving video distribution over IP Multicast networks and combines NGN video routing capabilities with a powerful video redundancy switch. It is designed to guarantee an ongoing, error-free signal flow and to simplify your IP network setups. As the latest and most advanced product in the X-Bar family, the X-Bar IVRA-210 is the perfect solution for all digital TV platforms that have provide highest service availability.



DESCRIPTION

The X-Bar IVRA-210 is able to select for each service one of two available input streams and produce an interruption-free output stream. If the current active input fails, the X-Bar IVRA-210 will automatically switch to the backup stream. By paying attention to Group of Pictures (GOP) and increasing sequence numbers of MPEG transport- and RTP-streams the output remains valid and is decodable at all times.

Even in platforms with N+1 redundancy setups or no redundancy at all, the GMIT IVRA-210 improves the availability of all services. Through constant input monitoring and analysis, a faulty input stream is detected immediately and the GMIT IVRA-210 can notify the global NMS by sending a SNMP message. It can even keep the signal flowing by inserting a definable pre-recorded failure-video.

Optimized for media delivery over NGN/IP networks, the X-Bar IVRA-210 is equipped with up to eight Gigabit Ethernet Ports. This allows to establish direct interconnections with numerous devices and consequently reduces costs, rack spacing and configuration

efforts for additional network infrastructure: Additional network switches are not necessary any more.

As first NGN Video Router available, the X-BAR IVRA-210 is able to handle all data as video services, not just IP packets. This combines all advantages of ASI or SDI based video distribution with cost efficiency of IP network infrastructure.

PRODUCT BENEFITS

- Optimized for All-IP systems – Equipped with up to 8 Gigabit Ethernet Interfaces, the X-Bar IVRA-210 makes additional network switches obsolete and simplifies your network
- Seamless failover with no dropouts – The decoder stays synchronized and streaming sessions will be kept alive, even if no backup stream is available
- Protect your services from unreliable IP networks and faulty setups. – Duplicated IP addresses will no longer be able to cause any distortions and dropped packets can be repaired using powerful FEC algorithms



KEY FEATURES

- Continuous input monitoring with immediate failure detection
- Content-sensitive TS/RTP switching at GOP borders
- TS/RTP timestamp synchronization at the output guaranteed
- Stream protection using high-performance source filtering algorithms (avoiding duplicated transmissions on one multicast sockets)
- Stream reparation performing automatic packet re-ordering and de-jittering
- Local failure-video insertion for services with no backup stream
- PRO MPEG FEC (COP 3) decoding and encoding
- Internal redundancy module for 1+1 operation with second X-Bar IVRA-210
- Built-in web-server for easy configuration and monitoring
- SNMP based integration in existing video headends

TECHNICAL SPECIFICATION

Interfaces

- 8 x Gigabit Ethernet for Input/Output
- 2 x Gigabit Ethernet for Management
- Up to 4 x ASI (optional)

Input/Output

- MPEG single/multiple program transport streams (ISO/IEC 13818-1 compliant)
- RTP / RTCP streams (RFC 3550 compliant)
- IP/UDP Data Streams (RFC 768 compliant)
- Pro MPEG (COP 3) FEC packets for stream reparation (FEC decoder & encoder)

GOP Switching

- MPEG-2 video codec (ISO/IEC 13818-2 compliant)
- H.264 (MPEG-4 AVC) video codec (ISO/IEC 14496-10 compliant)

Administration & Monitoring

- Remote: Web-based UI and SNMPv2 Control
- SNMP trap alarming for input failures

Hardware

- 1 U rackmount
- Dimensions: 44mm (H) x 430 mm (W) x 392 mm (D)
- Weight (net): 8,2 kg
- Weight (gross): 9,8 kg
- Operating Temperature: 0 °C – +45 °C
- Storage Temperature: -20 °C – +70 °C
- Humidity: 10 % - 95 % RH, non condensing
- Power: 60 W (avg.)

Redundant Setup

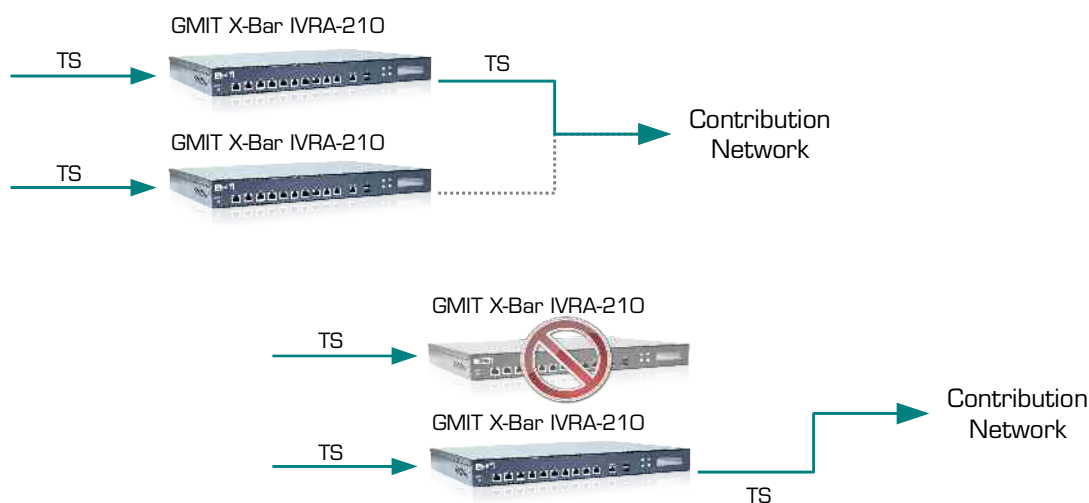

Contact

GMIT GMBH

Novalisstr. 10
10115 Berlin
Germany

PHONE: +49 30 240 88 23 30

FAX: +49 30 240 88 23 59

WEB: www.gmit-gmbh.de

E-MAIL: info@gmit-gmbh.de

GET MORE INFORMATION

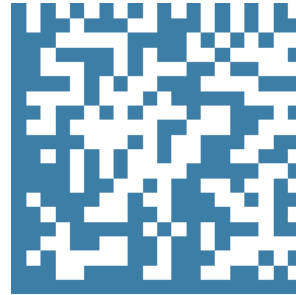

MORE GMIT PRODUCTS

Broadcast Multiscreen Monitor



Interactive Radio



GMIT is a component supplier providing headend technology and interactivity for digital and mobile broadcast. Our software products for stationary and mobile TV are optimized to satisfy the essential needs for reliability, economy and flexibility.